

| REVISIONS |                                   |      |    |     |      |
|-----------|-----------------------------------|------|----|-----|------|
| REV       | DESCRIPTION                       | DATE | DR | CHK | APPR |
| A         | ENGINEERING RELEASE PER ERO#10779 |      |    |     |      |

**HAL COMPUTERS LTD.**  
 WYBHAM LANE

New Address:  
 HAL COMPUTERS LTD.  
 INVINCIBLE ROAD,  
 FARNBOROUGH,  
 HANTS. GU14 7QU.  
 TEL: 0252 517171.

WEYB  
 telephone: 0932 485707

KT15 3NU  
 telex: 8813487

**PRODUCT SPECIFICATIONS**  
**MINI**  
**DOUBLE SIDED RECORDING**  
**FLEXIBLE DISK DRIVE**  
**MODEL TM100-2**  
**48 TPI DSR**

|   |                    |                  |          |  |
|---|--------------------|------------------|----------|--|
| <small>THE INFORMATION CONTAINED HEREON IS THE PROPERTY OF TANDON MAGNETICS. NO PORTION OF THIS DATA SHALL BE REPRODUCED, DISCLOSED, USED OR DUPLICATED FOR USE IN RECONSTRUCTION OR MANUFACTURING WITHOUT SPECIFIC WRITTEN PERMISSION FROM TANDON MAGNETICS.</small> | SIGNATURES.        |                  | DATE     |   |
|   | DR.                |                  |          |  |
|   | CHK                |                  |          |  |
|   | DES                |                  |          |  |
| <small>UNLESS OTHERWISE SPECIFIED DIMENSIONS ARE IN INCHES</small><br><small>TOLERANCES:</small><br>JOK ±<br>JOKK ±<br>X ±<br>X ±<br><small>BREAK ALL SHARP CORNERS APPROX. .010</small>  | ANGULAR:<br>± 1/2° |                  |          | <small>TITLE</small><br><b>MODEL TM100-2</b><br><b>PRODUCT SPEC: -</b><br><b>MINI-DOUBLE SIDED RECORDING FLEXIBLE DISK DRIVE</b> |
|   | ENGR.              |                  |          |  |
|   | PROJ. ENGR MATTSON |                  | 1218 704 |  |
| FINISH:   | MATERIAL:          |                  |          | <small>SIZE</small><br><b>A</b>  |
|   |                    |                  |          | <small>CODE IDENT NO.</small><br><b>179002</b>   |
|   |                    |                  |          | <small>DWG NO.</small><br><b>179002</b>  |
|   |                    |                  |          | <small>REV</small><br><b>C</b>   |
| SCALE   |                    | DO NOT SCALE DWG |          | <small>SHEET 1 OF 15</small>   |

| REVISIONS |             |      |    |     |      |
|-----------|-------------|------|----|-----|------|
| REV       | DESCRIPTION | DATE | DR | CHK | APPR |
|           | SEE PAGE 1  |      |    |     |      |

## 1.0 SCOPE

The Tandon Magnetics Corporation Flexible Disk Drive is a compact Data Storage device utilizing an Industry Standard 5.25 inch Diskette (133.4mm).

The Flexible Disk Drive provides double density capability when a Modified Frequency Modulated (MFM) or other appropriate Recording Technique is utilized. The encoding and decoding of the data is the user's responsibility.

### 1.1 WRITE PROTECT (STANDARD)

When a Write Protected Diskette is inserted in the Flexible Disk Drive, the Write Electronics are disabled.

### 1.2 BUSY INDICATOR (STANDARD)

A Busy Indicator located on the Front Panel will become illuminated when the Flexible Disk Drive is selected.

### 1.3 DAISY CHAIN CAPABILITY (STANDARD)

The unit provides Address Selection and gating Functions necessary to Daisy-chain a maximum of four (4) Drives at the user's option. The last unit on the Daisy Chain terminates the Interface. The terminations are accomplished by a resistor array plugged into a D.I.P. Socket.

### 1.4 INTERNAL TRIM ERASE (STANDARD)

The Flexible Disk Drive provides internally the necessary control signal for proper Trim erasure of Data.

|  |                  |                   |          |       |
|--|------------------|-------------------|----------|-------|
| <b>Tandon</b>  |                  |                   |          |       |
| TITLE<br>MODEL TM100-2<br>PRODUCT SPEC -<br>MINI-DOUBLE SIDED RECORDING<br>FLEXIBLE DISK DRIVE |                  |                   |          |       |
| SIZE<br>A  | CODE IDENT NO.   | DWG NO.<br>179002 | REV<br>C |       |
| SCALE  | DO NOT SCALE DWG |                   | SHEET 2  | OF 15 |

| REVISIONS |             |      |    |     |      |
|-----------|-------------|------|----|-----|------|
| REV       | DESCRIPTION | DATE | DR | CHK | APPR |
|           | SEE PAGE 1  |      |    |     |      |

**2.0 PERFORMANCE CHARACTERISTICS**

**2.1.1 HEADS**

Two (Double Sided Recording) T.M.C. Patented Design (one Fixed - one Gimbaled).  
Wear guaranteed 20,000 hours in media contact.

**2.1.2 TRACKS:**

40 per side 80 total  
.529 mm (20.8 milli inch) Spacing  
34.39 mm Track Radius (inside) side 1

**2.1.3 RECORDING:**

231.37 FR/mm (5877BPI MFM) inside track, Head #1  
125 K Bits/Sec (Single Density)  
25 K Bits/Track (Unformatted Single Density)  
2.00 Mega Bits/Diskette (Unformatted Single Density)

**2.1.4 MEDIA**

133.4 mm (5.25 Inch) Industry Standard Diskette  
3.6 x 10<sup>6</sup> Passes per Track Minimum wear guarantee

**2.1.5 DISK SPEED**

300 R.P.M. ± 1.5%  
I.S.V. ± 3%  
Latency 100ms Nominal  
250 Milli-Sec Start Time MAX  
150 Milli-Sec Stop Time MAX

**2.1.6 ACCESS TIME**

5.0 Millisec - Track to Track  
15 Millisec - Heads Settle Time

|  |                  |                   |               |
|--|------------------|-------------------|---------------|
| <b>Tandon</b>  |                  |                   |               |
| TITLE<br>MODEL TM100-2<br>PRODUCT SPEC -<br>MINI-DOUBLE SIDED RECORDING<br>FLEXIBLE DISK DRIVE |                  |                   |               |
| SIZE<br>A  | CODE IDENT NO.   | DWG NO.<br>179002 | REV<br>C      |
| SCALE  | DO NOT SCALE DWG |                   | SHEET 3 OF 15 |

| REVISIONS |             |      |    |     |      |
|-----------|-------------|------|----|-----|------|
| REV       | DESCRIPTION | DATE | DR | CHK | APPR |
|           | SEE PAGE 1  |      |    |     |      |

2.1.7 ERROR RATES (MAXIMUM)

One Recoverable error in  $10^9$  Bits.

One non-Recoverable Error in  $10^{12}$  Bits.

One seek error in  $10^6$  seeks.

These error rates are exclusive of external sources, i.e. user Electronics, Defective Diskette, Contaminated Diskette, etc.

2.1.8 ELECTRO-MAGNETIC CHARACTERISTICS

The TMC Flexible Disk Drive is designed to minimize electrical interference generated internally, and propagated through Space or on Associated Conductors.

|   |                  |         |               |  |
|---|------------------|---------|---------------|--|
| <b>Tandon</b>   |                  |         |               |  |
| TITLE   |                  |         |               |  |
| MODEL TM100-2<br>PRODUCT SPEC -<br>MINI-DOUBLE SIDED RECORDING<br>FLEXIBLE DISK DRIVE |                  |         |               |  |
| SIZE  | CODE IDENT NO.   | DWG NO. | REV           |  |
| A   |                  | 179002  | C             |  |
| SCALE   | DO NOT SCALE DWG |         | SHEET 4 OF 15 |  |

| REVISIONS |             |      |    |     |      |
|-----------|-------------|------|----|-----|------|
| REV       | DESCRIPTION | DATE | DR | CHK | APPR |
|           | SEE PAGE 1  |      |    |     |      |

**3.0 ENVIRONMENTAL SPECIFICATIONS**

3.1 The Drive will meet its operational specifications under the following environmental conditions:

3.1.1 TEMPERATURE

10°C to 44°C (50°F to 112°F) Operating  
 -40°C to 71°C (-40°F to 160°F) Non operating

3.1.2 RELATIVE HUMIDITY

20 - 80% Operating (Non condensing)  
 5 - 95% Non operating (Non condensing)

3.1.3 ALTITUDE

304.8 m (500 ft) below Sea Level to 15,240 m (50,000 ft) above Sea Level Operating or Non Operating.

3.1.4 SHIPMENT

When prepared for shipment by TMC, it will meet the requirements of NSTA Pre-Shipment Test Procedure Project 1A.

|   |                  |                          |                             |  |
|---|------------------|--------------------------|-----------------------------|--|
| <b>Tandon</b>   |                  |                          |                             |  |
| TITLE<br><b>MODEL TM100-2<br/>         PRODUCT SPEC —<br/>         MINI-DOUBLE SIDED RECORDING<br/>         FLEXIBLE DISK DRIVE</b> |                  |                          |                             |  |
| SIZE<br><b>A</b>  | CODE IDENT NO    | DWG NO.<br><b>179002</b> | REV<br><b>C</b>             |  |
| SCALE   | DO NOT SCALE DWG |                          | SHEET <b>5</b> OF <b>15</b> |  |

| REVISIONS |             |      |    |     |      |
|-----------|-------------|------|----|-----|------|
| REV       | DESCRIPTION | DATE | DR | CHK | APPR |
|           | SEE PAGE 1  |      |    |     |      |

4.0 MOUNTING

4.1 The Flexible Disk Drive may be mounted in any of the following planes: (Upright, Horizontal or Vertical). When mounted horizontally, recording Head #1 (top) must be the upper most head. Mounting holes are provided in various locations for attachments to user supplied mounting Brackets. See Figure #1.

4.2 PHYSICAL DIMENSION AND WEIGHT

4.2.1 Figure #1 illustrates the Physical Dimensions of TMC Flexible Disk Drive. Summarized as follows:

- Weight: 2.04 Kg (4.5 lb)
- Height: 85.85 mm (3.38 inches)
- Width: 149.1 mm (5.87 inches)
- Length: 203.2 mm (8.0 inches)

|  |                  |                   |               |
|--|------------------|-------------------|---------------|
| <b>Tandon</b>  |                  |                   |               |
| TITLE<br>MODEL TM100-2<br>PRODUCT SPEC —<br>MINI-DOUBLE SIDED RECORDING<br>FLEXIBLE DISK DRIVE |                  |                   |               |
| SIZE<br>A  | CODE IDENT NO.   | DWG NO.<br>179002 | REV.<br>C     |
| SCALE  | DO NOT SCALE DWG |                   | SHEET 6 OF 15 |

| REVISIONS |             |      |    |     |      |
|-----------|-------------|------|----|-----|------|
| REV       | DESCRIPTION | DATE | DR | CHK | APPR |
|           | SEE PAGE 1  |      |    |     |      |

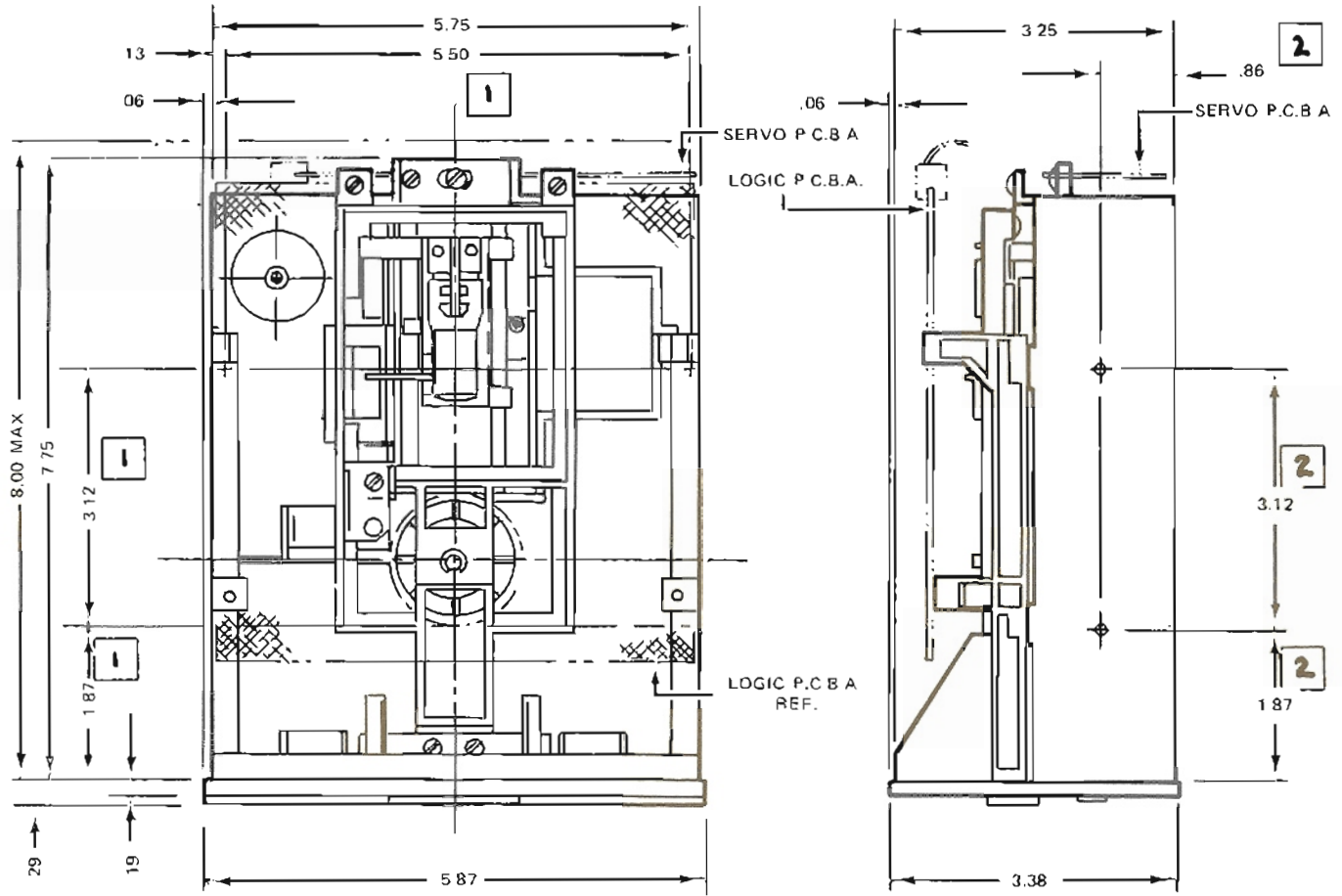

FIGURE 1

- 1** FOUR (4) MOUNTING HOLES ON UNIT FAR SIDE (BOTTOM). No. 6-32 UNC-2B x .31 DP.
- 2** FOUR (4) MOUNTING HOLES, TWO (2) ON EACH SIDE No. 6-32 UNC-2B x .31 DP.

|  |                  |                          |                 |       |
|--|------------------|--------------------------|-----------------|-------|
| <h1>Tandon</h1>  |                  |                          |                 |       |
| TITLE<br><b>MODEL TM100-2<br/>PRODUCT SPEC -</b><br>MINI-DOUBLE SIDED RECORDING<br>FLEXIBLE DISK DRIVE |                  |                          |                 |       |
| SIZE<br><b>A</b>   | CODE IDENT NO.   | DWG NO.<br><b>179002</b> | REV<br><b>C</b> |       |
| SCALE  | DO NOT SCALE DWG |                          | SHEET 7         | OF 15 |

| REVISIONS |             |      |    |     |      |
|-----------|-------------|------|----|-----|------|
| REV       | DESCRIPTION | DATE | DR | CHK | APPR |
|           | SEE PAGE 1  |      |    |     |      |

**5.0 POWER REQUIREMENTS**

**5.1 D. C. POWER SEQUENCING**

One second maximum from the Time Power is applied to the time when the unit will accept command.

**5.2 PRIMARY POWER**

+12 VDC  $\pm$  0.6 VDC @ 900 MA (AVE. MAX)

+5 VDC  $\pm$  0.25 VDC @ 600 MA (AVE. MAX) with < 100 MV P/P RIPPLE

**5.3 CONNECTOR P3/J3**

DC Power is supplied to the Flexible Disk Drive through a four (4) pin AMP connector PN-350211-1 soldered to the P.C.B.A. (J3). The mating Connector (not supplied) is AMP PN-1-480424-0 utilizing AMP contact PN-60619-1. See Table 1 for pin assignments.

|   |                  |                          |                 |  |
|---|------------------|--------------------------|-----------------|--|
| <b>Tandon</b>   |                  |                          |                 |  |
| TITLE<br><b>MODEL TM100-2<br/>         PRODUCT SPEC -</b><br>MINI-DOUBLE SIDED RECORDING<br>FLEXIBLE DISK DRIVE |                  |                          |                 |  |
| SIZE<br><b>A</b>  | CODE IDENT NO.   | DWG NO.<br><b>179002</b> | REV<br><b>C</b> |  |
| SCALE   | DO NOT SCALE DWG |                          | SHEET 8 OF 15   |  |



| REVISIONS |             |      |    |     |      |
|-----------|-------------|------|----|-----|------|
| REV       | DESCRIPTION | DATE | DR | CHK | APPR |
|           | SEE PAGE 1  |      |    |     |      |

TABLE 1

DC POWER CONNECTOR PIN ASSIGNMENT, P3/J3

| PIN | SUPPLY VOLTAGE |
|-----|----------------|
| 1   | + 12vdc        |
| 2   | 12v Return     |
| 3   | 5v Return      |
| 4   | + 5vdc         |

TABLE 1A

| PIN                                  | SIGNAL                            |
|--------------------------------------|-----------------------------------|
| GND LUG<br>3/16" QUICK<br>DISCONNECT | CHASSIS GROUND FROM<br>CONTROLLER |

**Tandon**

TITLE

MODEL TM100-2  
PRODUCT SPEC —  
MINI-DOUBLE SIDED RECORDING  
FLEXIBLE DISK DRIVE

|           |                  |                   |               |
|-----------|------------------|-------------------|---------------|
| SIZE<br>A | CODE IDENT NO.   | DWG NO.<br>179002 | REV<br>C      |
| SCALE     | DO NOT SCALE DWG |                   | SHEET 9 OF 15 |

| REVISIONS |             |      |    |     |      |
|-----------|-------------|------|----|-----|------|
| REV       | DESCRIPTION | DATE | DR | CHK | APPR |
|           | SEE PAGE 1  |      |    |     |      |

## 6.0 INTERFACE

6.1 The I/O is an Industry Compatible Interface. The Connector is (P1/J1) a 34 pin edge card connector (J1).

The mating connector (P1 not supplied) may be a Scotch-Flex Ribbon connecting, 3M PN-3463-001 or alternatively an AM PN-583717-5 utilizing contacts PN-1-583616-1 for Twisted pair. Signal Connector pin assignments can be found in Table 2.

### 6.1.1 INPUT CONTROL LINES

#### 6.1.1.1 DRIVE SELECT LINES

The DRIVE SELECT lines provide a means of selecting and deselecting a disk drive. These four lines select one of the four disk drives attached to the controller.

When the signal logic level is true (low), the disk drive electronics are activated, the head is loaded and the drive is conditioned to respond to Step or Read/Write commands. When the signal line logic level is false (high), the input control lines and output status lines are disabled.

A DRIVE SELECT line must remain stable in the true (low) state until the execution of a Step or Read/Write command is completed.

The disk drive address is determined by a Select Shunt on the signal PCBA. DRIVE SELECT lines 0 through 3 provide a means of daisy-chaining a maximum of four disk drives to a controller. Only one line can be true (low) at a time. An undefined operation might result if two or more units are assigned the same address or if two or more DRIVE SELECT lines are in the true (low) state simultaneously.

#### 6.1.1.2 MOTOR ON

When this signal line logic level goes true (low), the drive motor accelerates to its nominal speed of 300 RPM and stabilizes at this speed in less than 250 milliseconds. When the signal line logic level goes false (high), the disk drive decelerates to a stop in less than 150 milliseconds. This signal is not gated with select.

#### 6.1.1.3 DIRECT SELECT and STEP Lines (2 Lines)

When the disk drive is selected, a true (low) pulse with a time duration greater than 1 usec, but less than 2 msec, on the STEP line initiates the access motion. The direction of motion is determined by the logic state of the DIRECTION SELECT line when a STEP pulse is issued. The motion is towards the center of the disk if the DIRECTION SELECT line is in the true (low) state when a STEP pulse is issued. The direction of motion is away from the center of the disk if the DIRECTION SELECT line is in the false (high) state when a STEP pulse is issued. To ensure proper positioning, the DIRECTION SELECT line should be stable 1 usec (minimum), prior to issuing a corresponding STEP pulse and remain true (low) until 1 usec after the STEP pulse. The access motion is initiated on the trailing edge of the STEP pulse.

The time period between consecutive trailing edges of STEP pulses should not be less than 5 msec.

|  |                  |                   |                |
|--|------------------|-------------------|----------------|
| <b>Tandon</b>  |                  |                   |                |
| TITLE<br>MODEL TM100-2<br>PRODUCT SPEC —<br>MINI-DOUBLE SIDED RECORDING<br>FLEXIBLE DISK DRIVE |                  |                   |                |
| SIZE<br>A  | CODE IDENT NO.   | DWG NO.<br>179002 | REV<br>C       |
| SCALE  | DO NOT SCALE DWG |                   | SHEET 10 OF 15 |

| REVISIONS |             |      |    |     |      |
|-----------|-------------|------|----|-----|------|
| REV       | DESCRIPTION | DATE | DR | CHK | APPR |
|           | SEE PAGE 1  |      |    |     |      |

TABLE 2

INTERFACE CONNECTOR PIN ASSIGNMENTS, J1/P1

| INPUT CONTROL LINES<br>(CONTROLLER-TO-DISK-DRIVE) |        |                        |
|---|--------|------------------------|
| GROUND  | SIGNAL | DESCRIPTION (MNEMONIC) |
| 1   | 2 ✓    | Connector Clamp        |
| 3   | 4 ✓    | (Spare)                |
| 5   | 6 ✓    | DRIVE SELECT 3         |
| 9   | 10 ✓   | DRIVE SELECT 0         |
| 11  | 12 ✓   | DRIVE SELECT 1         |
| 13  | 14 ✓   | DRIVE SELECT 2         |
| 15  | 16 ✓   | MOTOR ON               |
| 17  | 18 ✓   | DIRECTION SELECT       |
| 19  | 20 ✓   | STEP                   |
| 21  | 22 ✓   | COMPOSITE WRITE DATA   |
| 23  | 24 ✓   | WRITE ENABLE           |
| 31  | 32     | SIDE ONE SELECT        |
| OUTPUT STATUS LINES<br>(DISK-DRIVE-TO-CONTROLLER) |        |                        |
| 7   | 8 ✓    | INDEX/SECOTR           |
| 25  | 26 ✓   | TRACK 00               |
| 27  | 28 ✓   | WRITE PROTECTED        |
| 29  | 30 ✓   | COMPOSITE READ DATA    |
| 33  | 34 ✓   | Connector Clamp        |

**Tandon**

TITLE

MODEL TM100-2  
 PRODUCT SPEC -  
 MINI-DOUBLE SIDED RECORDING  
 FLEXIBLE DISK DRIVE

|           |                  |                   |                |
|-----------|------------------|-------------------|----------------|
| SIZE<br>A | CODE/IDENT NO.   | DWG NO.<br>179002 | REV<br>C       |
| SCALE     | DO NOT SCALE DWG |                   | SHEET 11 OF 15 |

| REVISIONS |             |      |    |     |      |
|-----------|-------------|------|----|-----|------|
| REV       | DESCRIPTION | DATE | DR | CHK | APPR |
|           | SEE PAGE 1  |      |    |     |      |

The Drive Electronics will ignore STEP pulses when either of the following conditions exist:

- (A) The WRITE ENABLE is true (low)
- (B) The direction SELECT is false (high) and the HEAD is position at track 00
- (C) The DRIVE is not selected

#### 6.1.1.4 COMPOSITE WRITE DATA

When the disk drive is selected, this interface line provides the bit-serial COMPOSITE WRITE DATA pulses that control the switching of the write current in the selected head. The write electronics must be conditioned for writing by the WRITE ENABLE line (see Para. 5.4.1.6).

For each high-to-low transition on the COMPOSITE WRITE DATA line, a flux change is produced at the write head gap. This will cause a flux change to be stored on the medium.

When a double-frequency type encoding technique is used in which data and clock form the combined Write Data signal, the following is recommended.

- (1) The repetition of the high-to-low transitions, when writing all zeros, should be equal to the nominal data rate,  $\pm 0.1\%$ .
- (2) The repetition rate of the high-to-low transitions, when writing all ones, should be equal to twice the nominal data rate,  $\pm 0.1\%$ .

#### 6.1.1.5 WRITE ENABLE

When this signal is true (low), the write electronics are prepared for writing data (the read electronics are disabled). This signal turns on write current in the selected Read/Write head. Data is written under the control of the COMPOSITE WRITE DATA and SIDE ONE SELECT input lines. It is generally recommended that changes of state on the WRITE ENABLE line occur before the first WRITE DATA pulse. When the WRITE ENABLE line is false (high), all write electronics are disabled.

When a write-protected diskette is installed in a drive, the write electronics are disabled irrespective of the state of the WRITE ENABLE or SIDE ONE SELECT lines.

#### 6.1.1.6 SIDE ONE SELECT

The SIDE-ONE SELECT interface line defines which side of a two-sided diskette is used for information transfer.

An open circuit of false (high) level selects the Read/Write head on SIDE 0 surface of the diskette. A true (low) level on this line selects the Read/Write head on SIDE 1 surface of the diskette.

A 100  $\mu$ sec minimum should be allowed for the Read circuit to stabilize after a head switching.

|   |                  |                   |                |
|---|------------------|-------------------|----------------|
| <b>Tandon</b>   |                  |                   |                |
| TITLE<br>MODEL TM100-2<br>PRODUCT SPEC --<br>MINI-DOUBLE SIDED RECORDING<br>FLEXIBLE DISK DRIVE |                  |                   |                |
| SIZE<br>A   | CODE IDENT NO.   | DWG NO.<br>179002 | REV<br>C       |
| SCALE   | DO NOT SCALE DWG |                   | SHEET 12 OF 15 |

| REVISIONS |             |      |    |     |      |  |
|-----------|-------------|------|----|-----|------|--|
| REV       | DESCRIPTION | DATE | DR | CHK | APPR |  |
|           | SEE PAGE 1  |      |    |     |      |  |

6.2.1 OUTPUT STATUS LINES

6.2.1.1 INDEX/SECTOR

The INDEX/SECTOR signal is a composite of the Index pulse and Sector signals.

An Index pulse is provided once every revolution (200 msec, nominal) to indicate to the controller the beginning of a track. The leading edge of this signal must always be used to insure timing accuracy. The INDEX/SECTOR line remains in the true (low) state for the duration of the INDEX/SECTOR pulse. The duration of the INDEX/SECTOR pulse is nominally 3.5 msec.

The Sector signal portion appears only when using hard-sectored diskettes.

6.2.1.2 TRACK 0

When the disk drive is selected, the TRACK 0 interface signal indicates to the controller that the Read/Write head is positioned on TRACK 0. The TRACK 0 signal remains true (low) until the head is moved away from TRACK 0.

6.2.1.3 WRITE PROTECTED

The NWPTD signal line level goes true (low) when the diskette is write protected, the write electronics are internally disabled.

With WRITE PROTECTED false (high), the write electronics are enabled and Write operations can be performed. It is generally recommended that the controller should not issue a Write command when the WRITE PROTECTED signal is true (low).

6.2.1.4 COMPOSITE READ DATA

This interface line transmits the readback data to the controller when the drive is selected. It provides a pulse for each flux transition recorded and detected on the diskette. The COMPOSITE READ DATA output line goes true (low) for a duration of  $1 \pm .25$  usec for each flux change recorded on diskette.

The leading edge of the COMPOSITE READ DATA output pulse represents the true positions of the flux transitions on the diskette surface.

|   |                  |         |                |
|---|------------------|---------|----------------|
| <b>Tandon</b>   |                  |         |                |
| TITLE   |                  |         |                |
| MODEL TM100-2<br>PRODUCT SPEC -<br>MINI-DOUBLE SIDED RECORDING<br>FLEXIBLE DISK DRIVE |                  |         |                |
| SIZE  | CODE IDENT NO.   | DWG NO. | REV            |
| A   |                  | 179002  | C              |
| SCALE   | DO NOT SCALE DWG |         | SHEET 13 OF 15 |

| REVISIONS |             |      |    |     |      |
|-----------|-------------|------|----|-----|------|
| REV       | DESCRIPTION | DATE | DR | CHK | APPR |
|           | SEE PAGE 1  |      |    |     |      |

7.0 TYPICAL INTERFACE CHARACTERISTICS

7.1 The output control lines have the following electrical specification:

True =  $V_{out} + 0.4V$  (MAX) @  $I_{out} = 48\text{ ma}$  (MAX)

False =  $V_{out} + 2.4V$  (MIN) (Open collector @  $I_{out} = 250\text{ ua}$  (MAX))

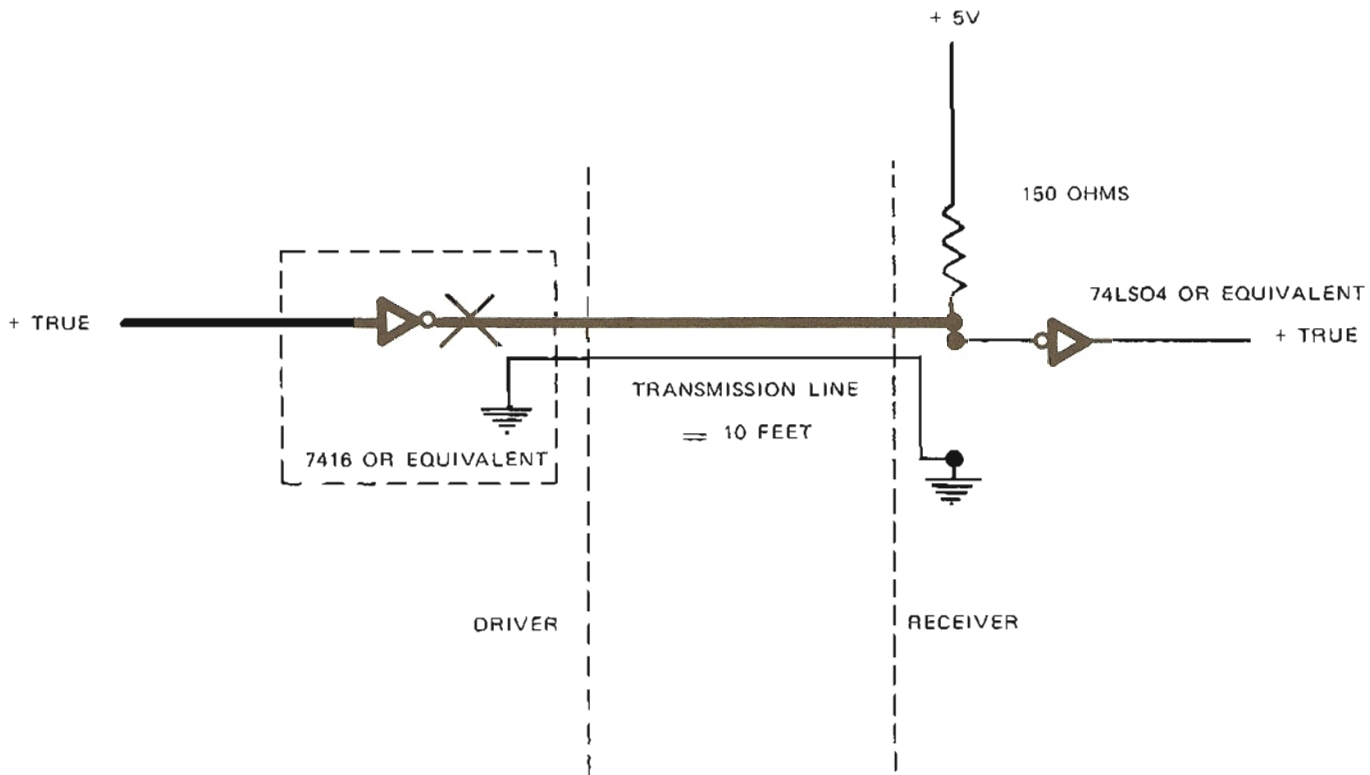
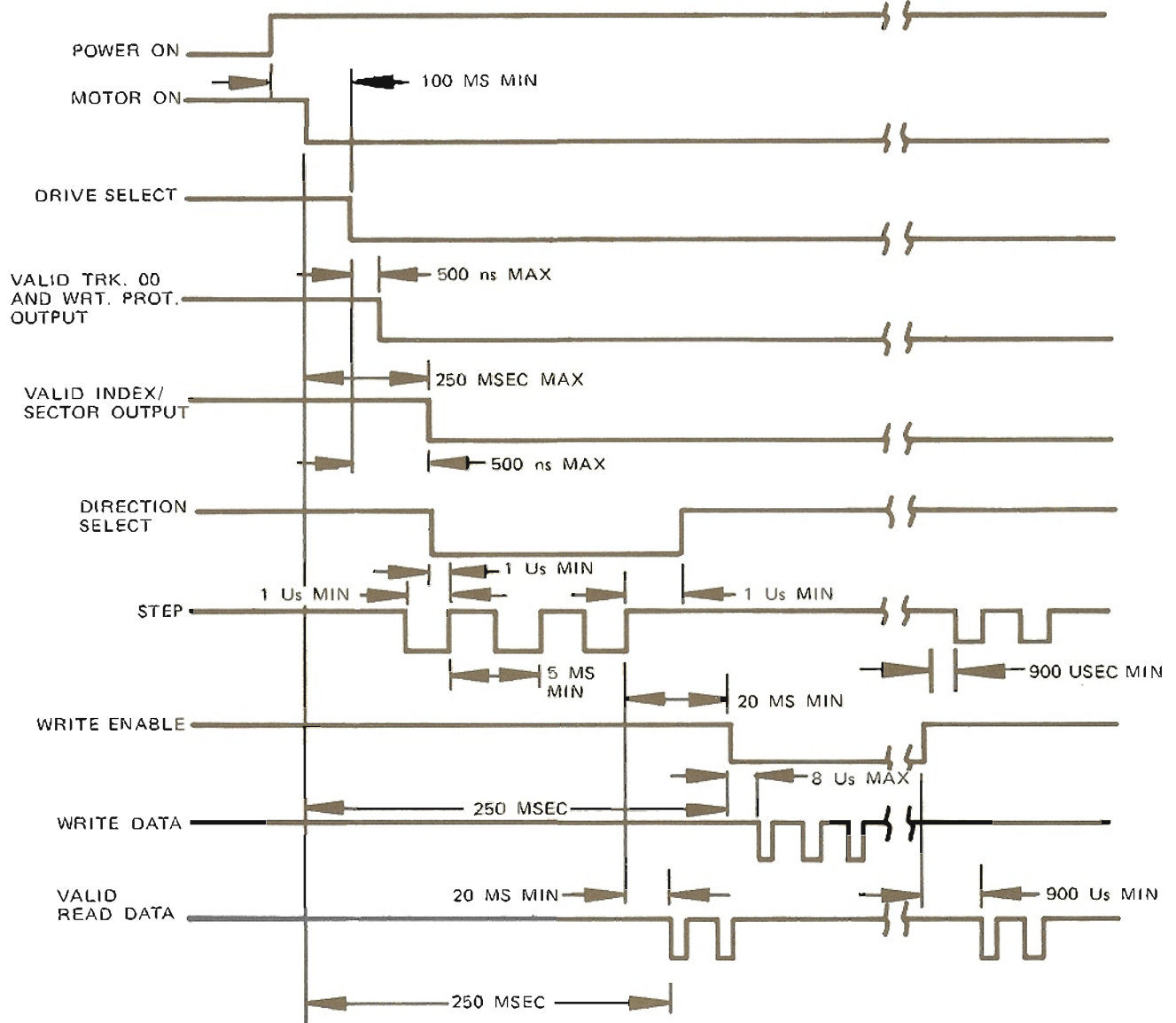

FIGURE 2

|   |                  |                   |                |
|---|------------------|-------------------|----------------|
| <b>Tandon</b>   |                  |                   |                |
| TITLE<br>MODEL TM100-2<br>PRODUCT SPEC --<br>MINI-DOUBLE SIDED RECORDING<br>FLEXIBLE DISK DRIVE |                  |                   |                |
| SIZE<br>A   | CODE IDENT NO    | DWG NO.<br>179002 | REV<br>C       |
| SCALE   | DO NOT SCALE DWG |                   | SHEET 14 OF 15 |

| REVISIONS |             |      |    |     |      |
|-----------|-------------|------|----|-----|------|
| REV       | DESCRIPTION | DATE | DR | CHK | APPR |
|           | SEE PAGE 1  |      |    |     |      |



MODEL TM-100 GENERAL CONTROL AND DATA TIMING REQUIREMENTS  
 FIGURE 3

|   |                  |                          |                              |
|---|------------------|--------------------------|------------------------------|
| <b>Tandon</b>   |                  |                          |                              |
| TITLE<br><b>MODEL TM100-2<br/>     PRODUCT SPEC -<br/>     MINI-DOUBLE SIDED RECORDING<br/>     FLEXIBLE DISK DRIVE</b> |                  |                          |                              |
| SIZE<br><b>A</b>  | CODE IDENT NO.   | DWG NO.<br><b>179002</b> | REV<br><b>C</b>              |
| SCALE   | DO NOT SCALE DWG |                          | SHEET <b>15</b> OF <b>15</b> |

